

NOVA Routing - CNC Machines

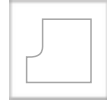

Grooving
& Sizing



Profiling &
Chamfering

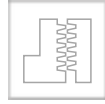

Jointing &
Rebating



Carving



Clamping
Systems &
Adapters

Solid Carbide Roughing Spiral Three Flute

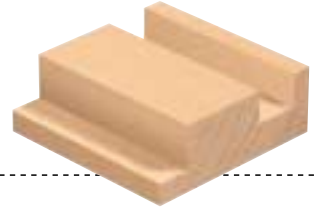
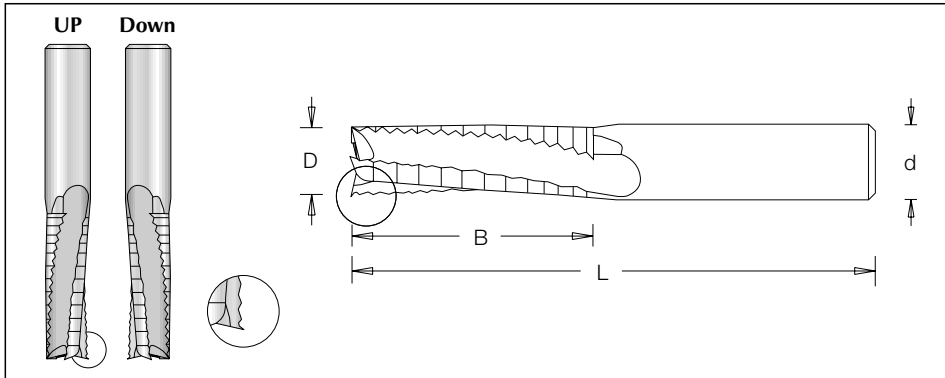

øD	Code No.		B	L	ød
	Upcut	Downcut			
10	178 632 7	178 932 7	32	80	10
12	178 635 9	178 935 9	32	80	12
	178 638 9	178 938 9	52	100	12
14	178 641 0	178 941 0	52	100	14
16	178 647 0	178 947 0	52	110	16
18	178 651 0	178 951 0	52	120	18
20	178 656 0	178 956 0	52	120	20
	178 658 0	178 958 0	72	135	20

Solid Carbide Chipbreaker Spiral Three Flute

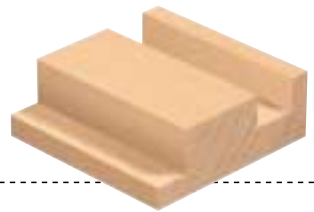
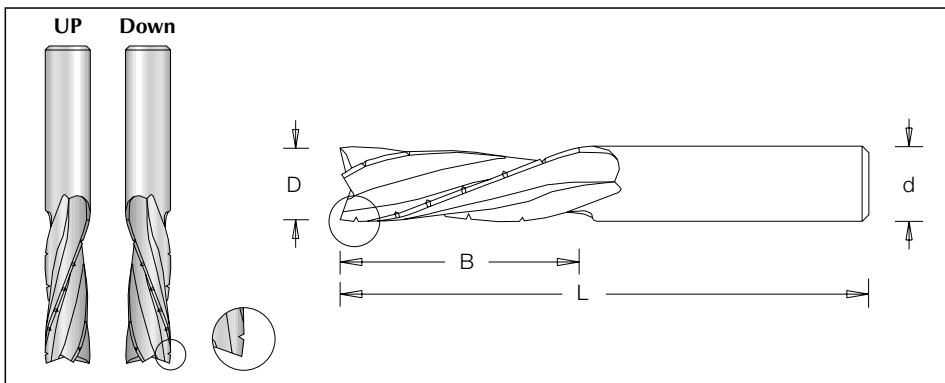

øD	Code No.		B	L	ød
	Upcut	Downcut			
10	178 433 7	178 533 7	42	80	10
12	178 437 9	178 537 9	42	80	12
14	178 439 0	178 539 0	35	80	14
16	178 447 0	178 547 0	55	100	16
	178 448 0	178 548 0	52	110	16
18	178 452 0	178 552 0	55	100	18
	178 451 0	178 551 0	52	120	18
20	178 457 0	178 557 0	55	100	20
	178 456 0	178 556 0	52	120	20

NOVA Routing - CNC Machines



Grooving & Sizing

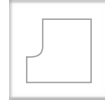

Profiling & Chamfering

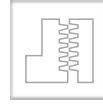

Jointing & Rebating



Carving



Clamping Systems & Adapters

Multiple Cutting Edge Up & Down Shear Router Cutter

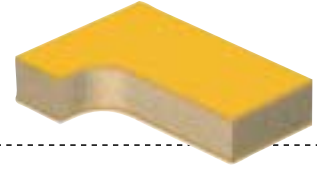
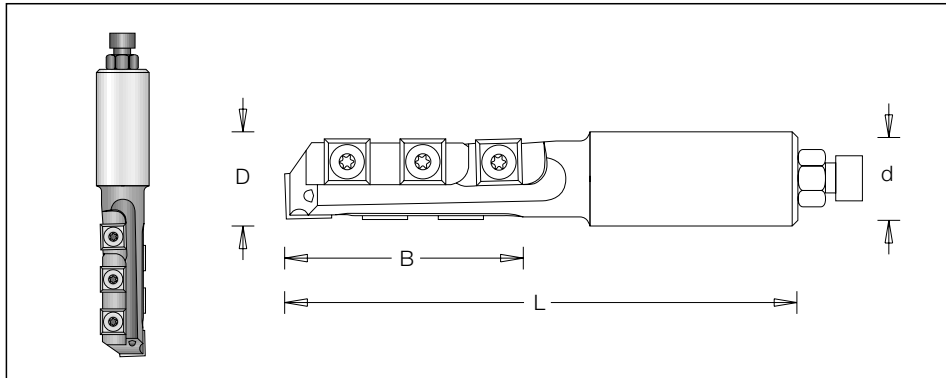

øD	Code No.	B	L	ød	n
22	807 310 H	42	115	25x55mm	28,000
	807 315 H	62	135	25x55mm	28,000

⚠ Also available with 20 mm diameter shank.

Spare Parts:



T.C. Blade
310 121 2
12x12x1.5



Torx screw
193 395 0
M4x8



Torx key
194 101 5
T - 15

Solid Carbide Straight Router Cutter Double Flute

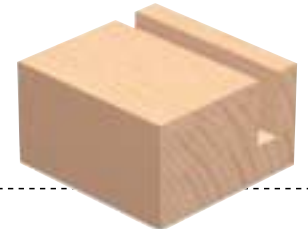
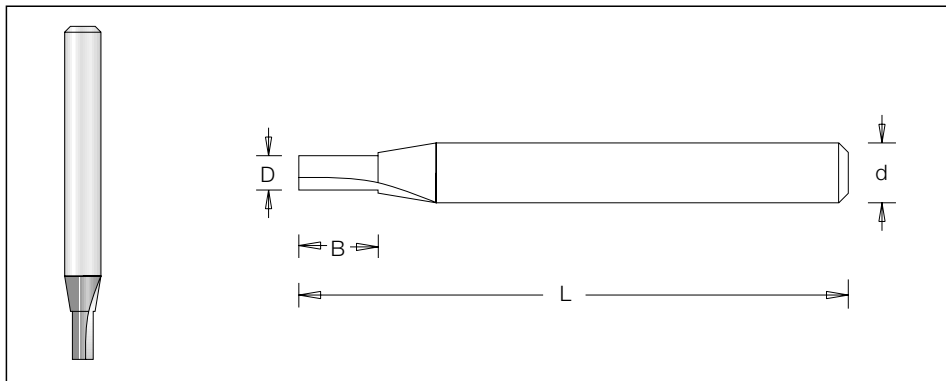

øD	Code No.	B	L	ød
3	so107 001 3	11	60	6
4	so107 004 3	11	60	6
5	so107 007 3	11	60	6
6	so107 010 3	19	60	6
	so107 013 3	25	60	6
8	so107 025 5	25	70	8
10	so107 858 7	30	80	10

NOVA Routing - CNC Machines

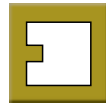

Grooving
& Sizing

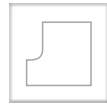

Profiling &
Chamfering

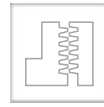

Jointing &
Rebating

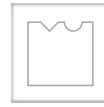

Carving



Clamping
Systems &
Adapters

Solid Carbide Double Flute Spiral

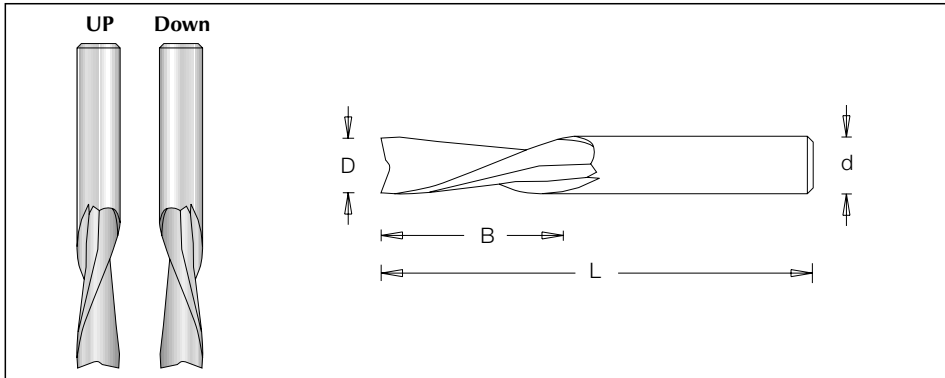

øD	Code No.		B	L	ød
	Upcut	Downcut			
3	173 405 0	173 505 0	12	50	3
4	173 410 0	173 510 0	12	55	4
5	173 416 0	173 516 0	20	55	5
6	173 420 3	173 520 3	20	60	6
8	173 426 5	173 526 5	25	60	8
10	173 430 7	173 530 7	25	70	10
	173 432 7	173 532 7	32	70	10
12	173 435 9	173 535 9	32	80	12
	173 437 9	173 537 9	42	90	12
	173 438 9	173 538 9	52	100	12
14	173 439 0	173 539 0	32	90	14
	173 440 0	173 540 0	42	90	14
	173 441 0	173 541 0	52	100	14
16	173 446 0	173 546 0	42	100	16
	173 447 0	173 547 0	52	110	16

Solid Carbide Double Flute Spiral - 8mm Shank

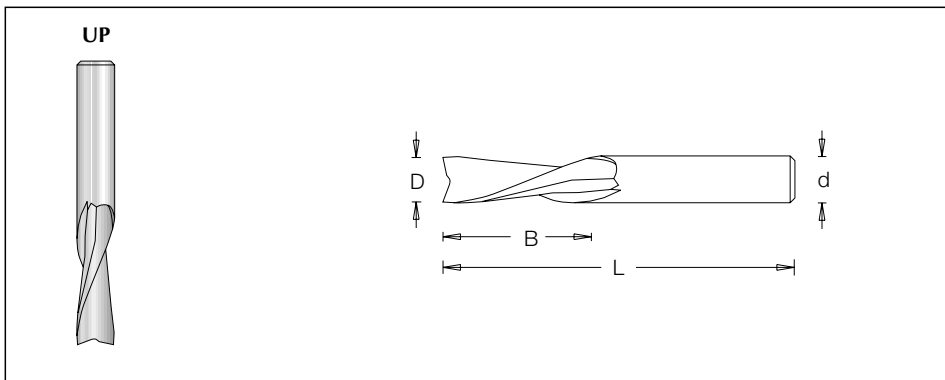

øD	Code No.	B	L	ød
3	173 405 5	12	50	8
4	173 410 5	12	50	8
5	173 415 5	15	50	8
6	173 420 5	20	60	8
8	173 425 5	20	60	8

NOVA Routing - CNC Machines

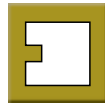

Grooving
& Sizing

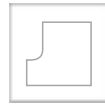

Profiling &
Chamfering

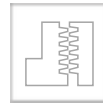

Jointing &
Rebating



Carving



Clamping
Systems &
Adapters

Solid Carbide Spiral Three Flute

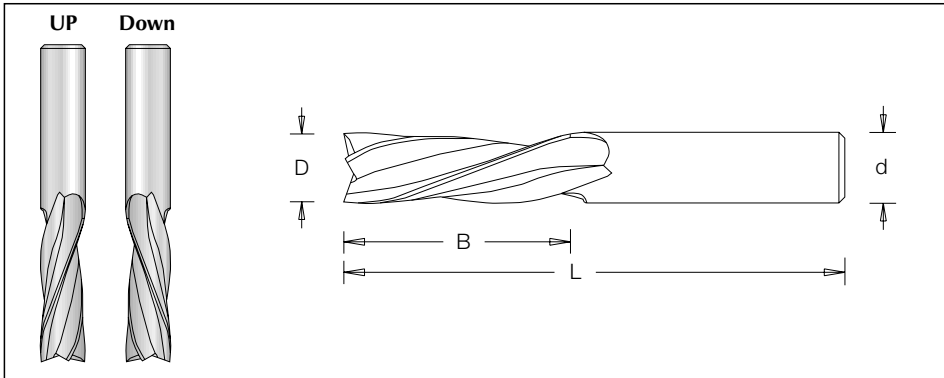

øD	Code No.		B	L	ød
	Upcut	Downcut			
12	173 637 9	173 937 9	42	80	12
	173 638 9	173 938 9	52	100	12
14	173 639 0	173 939 0	35	80	14
	173 670 0	173 970 0	42	100	14
	173 640 0	173 940 0	55	100	14
	173 641 0	173 941 0	35	80	16
16	173 646 0	173 946 0	42	100	16
	173 648 0	173 948 0	52	110	16
18	173 651 0	173 951 0	52	120	18
20	173 656 0	173 956 0	52	120	20
	173 658 0	173 958 0	72	135	20

NOVA Routing - CNC Machines

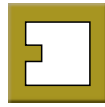

Grooving
& Sizing

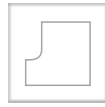

Profiling &
Chamfering

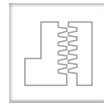

Jointing &
Rebating

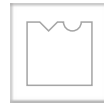

Carving



Clamping
Systems &
Adapters

Straight Router Cutter

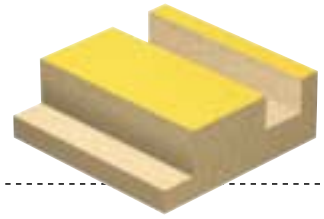
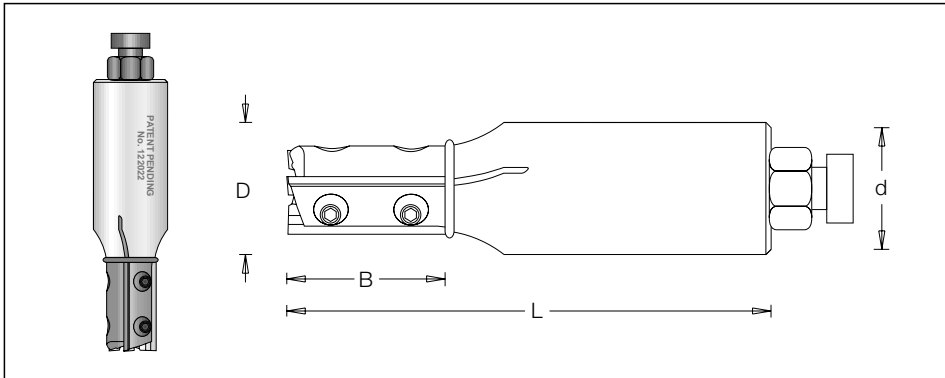

øD	Code No.	B	T.C. blade	L	ød	n
10	807 105 9 *	20	1	71.5	12	18,000
12	807 111 9 **	30	2	81.0	12	18,000
16	807 115 0	30	2	81.0	16	18,000
	807 116 0	50	2	101.0	16	18,000
18	807 120 0	30	3	81.5	18	18,000
	807 120 H	30	3	81.5	25	18,000
	807 121 0	50	3	101.5	20	18,000
	807 121 OL	50	3	101.5	20	18,000
20	807 123 0	30	3	81.5	20	18,000
	807 125 0	50	3	101.5	20	18,000
	807 125 H	50	3	101.5	25	18,000
	807 125 HL	50	3	101.5	25	18,000
18	807 121 H	50	3	101.5	25	18,000
	807 121 HL	50	3	101.5	25	18,000

⚠ L=Left Hand Rotation

Spare parts:



T.C. Blade



Allen screw *



Allen screw **



Allen screw



Torx key

B= 20 #310 751 0 20x5.5x1.1 #193 035 0 M3x4 #193 036 0 M3x5 #193 037 0 M3x6 #194102 0 S1.5

B= 30 #310 751 1 30x5.5x1.1

B= 50 #310 751 3 50x5.5x1.1

NOVA Routing - CNC Machines

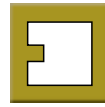

Grooving
& Sizing

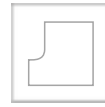

Profiling &
Chamfering

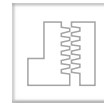

Jointing &
Rebating



Carving

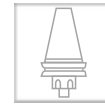

Clamping
Systems &
Adapters

Straight Router Cutter

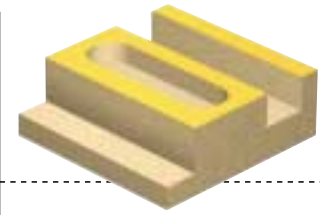
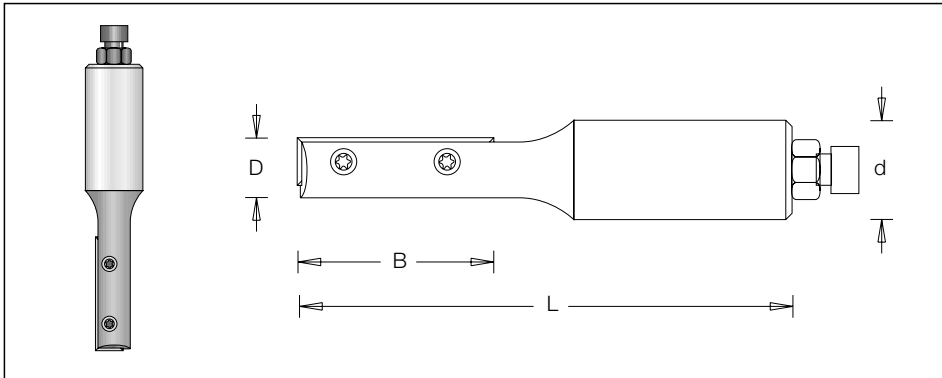

øD	Code No.	B	T.C. Blade	L	ød	n
12	107 350 H	30	1	105	25x55	18,000
14	107 354 H	30	1	105	25x55	18,000
	L 107 353 H	50	3	125	25x55	18,000
15	107 355 H	30	1	105	25x55	18,000
	107 356 H	50	3	125	25x55	18,000
16	107 358 H	30	2	105	25x55	18,000
	107 360 H	50	4	125	25x55	18,000

Also available with 20mm diameter shanks.

Spare Parts:



T.C. Blade 1
310 793 0
30x9x1.5



T.C. Blade 2
310 723 0
30x12x1.5



T.C. Blade 3
300 752 0
50x9x1.5



T.C. Blade 4
310 725 0
50x12x1.5



Torx screw
193 354 8
M3.5x6



Torx key
194 101 5
T15

NOVA Routing - CNC Machines



Grooving
& Sizing

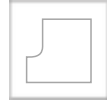

Profiling &
Chamfering

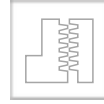

Jointing &
Rebating



Carving



Clamping
Systems &
Adapters

Straight Router Cutter with Plunge Center Tip

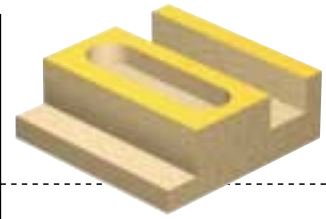
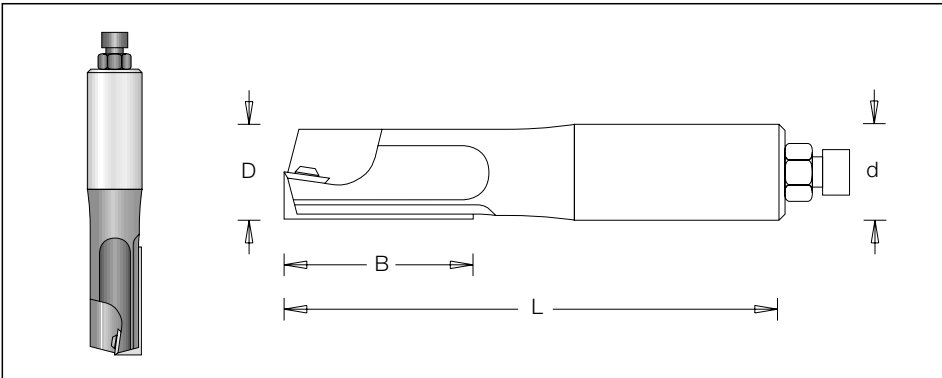

øD	Code No.	B	L	ød	n
16	107 373 H *	30	105	25x55	18,000
	107 374 H *	50	125	25x55	18,000
18	107 375 H	30	105	25x55	18,000
	107 376 H	50	125	25x55	18,000
20	107 377 H	30	105	25x55	18,000
	107 398 H	50	125	25x55	18,000
25	107 378 H	30	105	25x55	18,000
	107 399 H	50	125	25x55	18,000

! * Brazed center tip
Also available with 20 mm diameter shank.

Spare Parts:



T.C. Blade
310 723 0
30x12x1.5



T.C. Blade
310 725 0
50x12x1.5



Torx screw
193 395 0
M4x0.8



Torx screw
193 354 8
M3.5x0.6



Torx key
194 101 5
T15

B=30



T.C. Blade

B=50



T.C. Blade

D=18 310 752 6 310 752 3
7.5x12x1.5 7.5x12x1.5

D=20 310 752 6 310 751 2
7.5x12x1.6 7.5x12x1.5

D=25 310 752 3 310 751 2
7.5x12x1.6 7.5x12x1.5