

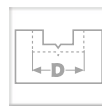

NOVA Drilling



CNC &
Automatic
Machines



Multi
Purpose
Boring



Slot
Mortising



Counter
Sinking &
Plug maker

Dirose™ Profile for Rosettes.

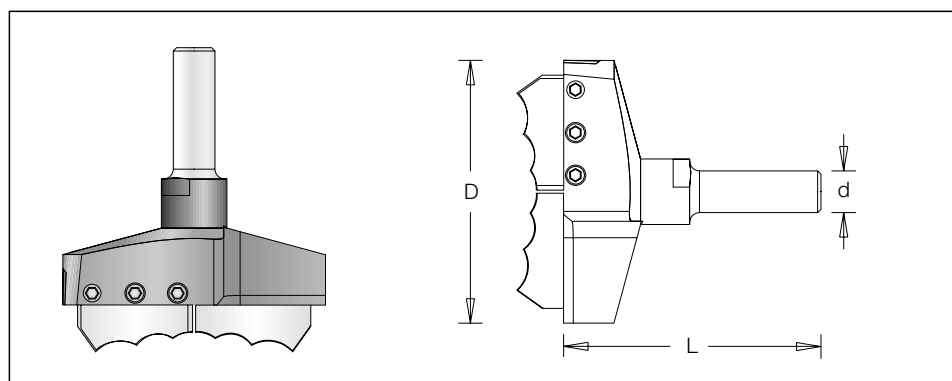

	øD	Code No.	L	ød	Profile
Dirose Set	79.6	180 100 9	81	12	5x2 - Profile knives as per your choice
Dirose	79.6	180 001 9	81	12	

- ⚠ Check that the speed is suitable for the type of wood being worked:
 MDF: 3000-6000 RPM
 Soft Wood: 3000-6000 RPM
 Hard Wood: 1500-2000 RPM

Dirose™ Cutter

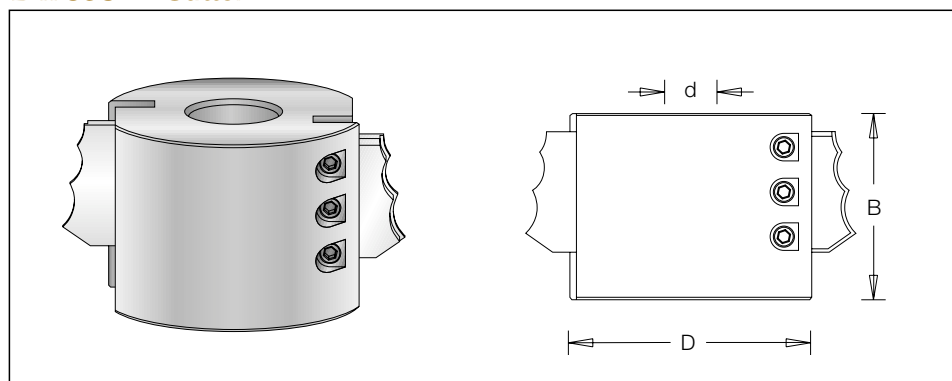

	øD	Code No.	B	ød	Profile
Dirose Cutter	74	180 002 1	54	30	
Dirose & Dirose Cutter Set		180 200 9			5x2 - Profile knives as per your choaie

- ⚠ Can be supplied with 5/8", 3/4" and 1".

Spare Parts:



Allen screw
#193 065 0



Allen key
1940090

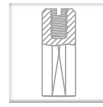

CNC &
Automatic
Machines

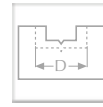

Multi
Purpose
Boring



Slot
Mortising



Counter
Sinking &
Plug maker

Dirose™ Profile Shapes Available

1800010 *	 43	1800090	 80
1800010	 51	1800100	 80
1800020 *	 50	1800100 *	 74
1800020	 58	1800110	 80
1800030	 60	1800120	 85
1800040	 57	1800120 *	 77
1800050	 70	1800130	 90
1800060	 70	1800130 *	 84
1800070	 70	1800140	 100
1800080	 80	1800150	 100

⚠ * With this knife it is possible to execute both a depressed rosette in the wood and a protruding rosette (button) for gluing.