

Grooving

Rebating

Profiling

Jointing

Frame &
Panel door

Lamello

Multi Profile
system

Adjustable Grooving Cutter with Scorers 4 - 7.5mm

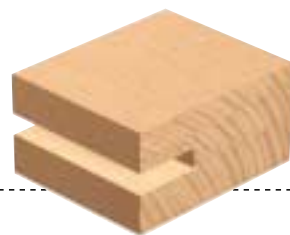
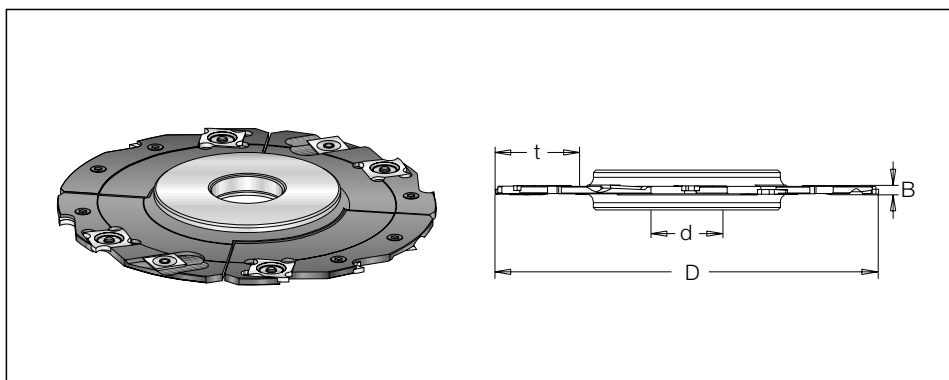

EN847-1
EN847-2



Hand
feed

øD	B	Code No.	Teeth	ød	Max. t	n
160	4.0-7.5	722 001 1	8+4	30	30	4,800 - 8,300
180	4.0-7.5	722 010 1	8+4	30	40	4,300 - 7,500

! Adjusting cutting widths, with spacers in increments of 0.1mm.

Spare parts:



T.C. Blade
#300 850 1
18x18x2



T.C. Blade
#300 850 2
14x14x1.2



Spacer set
#192 690 0
B= 3.5



T.C. Blade Nut
#192 360 0
M4x0.5x9.9



T.C. Blade Nut
#192 350 0
M4x0.5x11.1



Torx screw
#193 028 0
M4x3.2



Torx key
1941100
T9

Adjustable Grooving Cutter with Scorers 4 - 15.5mm

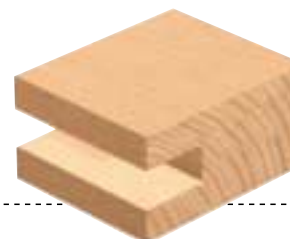
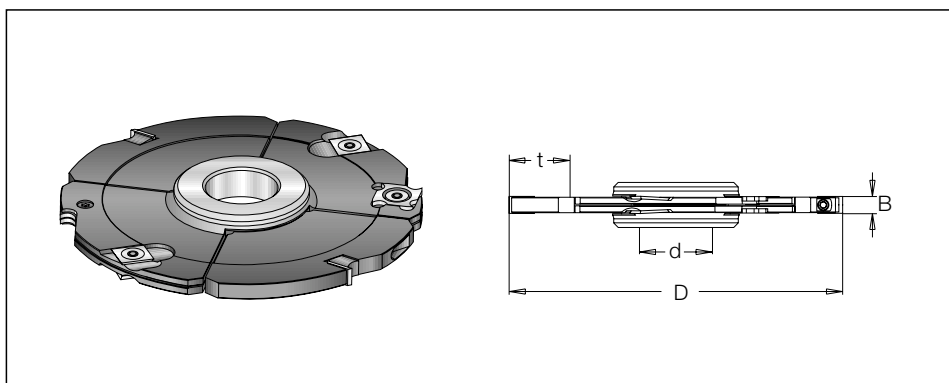

EN847-1
EN847-2



Hand
feed

øD	B	Code No.	Teeth	ød	Max. t	n
150	4.0-15.5	722 030 1	2+4+4	30	45	5,500 - 8,500

! Adjusting cutting widths, with spacers in increments of 0.1mm.

Spare parts:



T.C. Blade
#310 751 2
7.5x12x1.5



Wedge
#199 031 0
L=6.5



T.C. Blade
#300 850 1
18x18x2



T.C. Blade
#300 850 2
14x14x1.2



Spacer set
#192 619 0
B=8.1



T.C. Blade Nut
#192 360 0
M4x0.5x9.9



T.C. Blade Nut
#192 350 0
M4x0.5x11.1



Torx screw
#193 028 0
M4x3.2



Allen screw
#193 060 0
M5x16



Torx key
194 110 0
T9



Allen key
194 008 0
S2.5



NOVA Cutting



Grooving

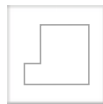

Rebating

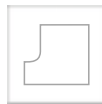

Profiling

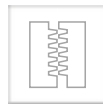

Jointing



Frame &
Panel door

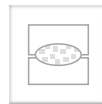

Lamello



Multi Profile
system

Adjustable Grooving Cutter (with ring nut) 4 - 7.5mm

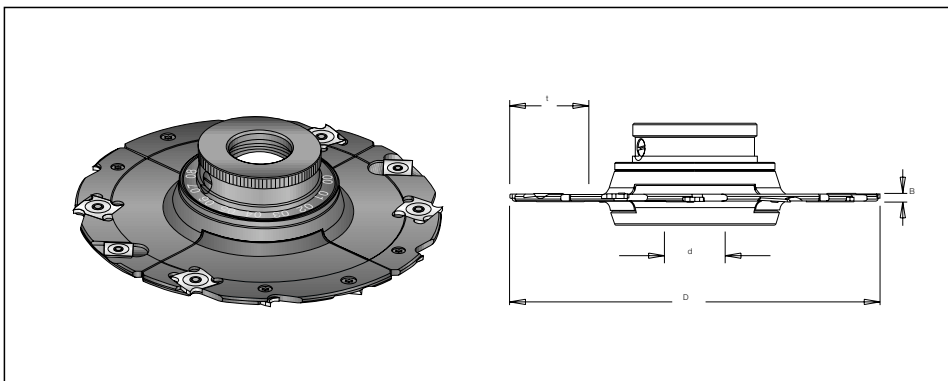

EN847-1
EN847-2



Hand
feed

øD	B	Code No.	Teeth	ød	Max. t	n
160	4.0-7.5	722 016 1	8+4	30	30	4,800 - 8,300
180	4.0-7.5	722 017 1	8+4	30	40	4,300 - 7,500

! For producing various grooving widths through continuous adjustment in a resolution scale of 0.1mm.

Spare parts:



T.C. Blade
#300 850 1
18x18x2



T.C. Blade
#300 850 2
14x14x1.2



T.C. Blade Nut
#192 360 0
M4x0.5x9.9



T.C. Blade Nut
#192 350 0
M4x0.5x11.1



Torx screw
#193 028 0
M4x3.2



Torx key
#194 110 0
T9



NOVA Cutting

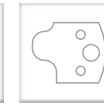
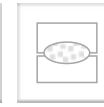
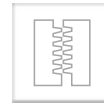
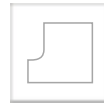
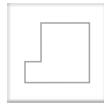
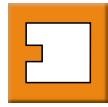

Grooving

Rebating

Profiling

Jointing

Frame &
Panel door

Lamello

Multi Profile
system

Adjustable Grooving Cutter with Scorers 8.0 - 24mm

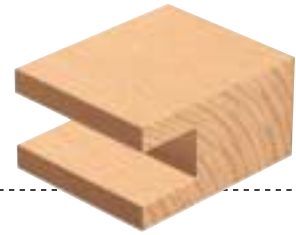
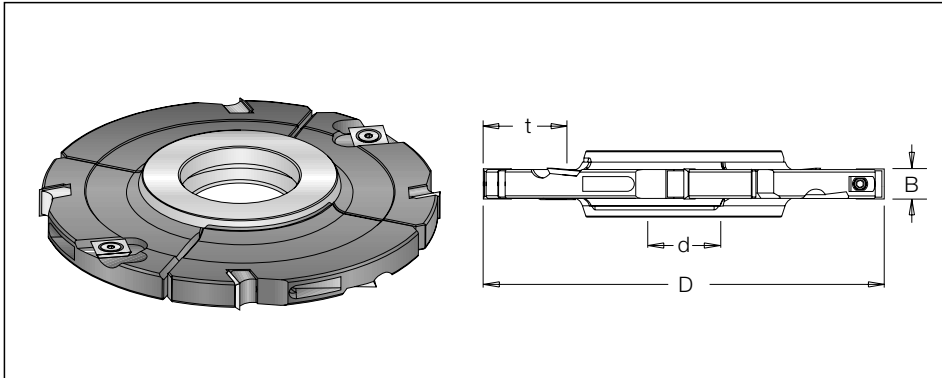

EN847-1
EN847-2



Hand
feed

øD	B	Code No.	Teeth	ød	Max. t	n
160	8.0-15.0	722 002 1	4+4	30	30	4,800 - 8,300
	12.5-24.0	722 003 1	4+4	30	30	4,800 - 8,300
180	8.0-15.0	722 004 1	4+4	30	40	4,300 - 7,500
	12.5-24.0	722 005 1	4+4	30	40	4,300 - 7,500

Adjusting cutting widths, with spacers in increments of 0.1mm.

Spare parts:



T.C. Blade



Wedge



T.C. Blade



Spacer set



Torx screw



Allen screw



Torx key



Allen key

B= 8-15mm	#310 751 2	#199 031 0	#300 850 3	#192 691 0	#193 370 0	#193 060 0	#194 106 0	#194 008 0
	7.5x12x1.5	L=6.5	14x14x2	B =7	M5x6.3	M5x16	T20	S2.5
B= 12.5-24mm	#300 750 9	#199 032 0	#300 850 3	#192 692 0	#193 370 0	#193 060 0	#194 106 0	#194 008 0
	11.6x12x1.5	L=10.5	14x14x2	B =11.5	M5x6.3	M5x16	T20	S2.5