

NOVA Cutting

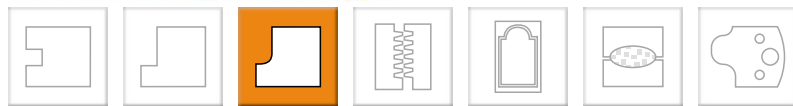

Grooving Rebating **Profiling** Jointing Frame & Panel door Lamello Multi Profile system

Corner Round / Cove Cutter

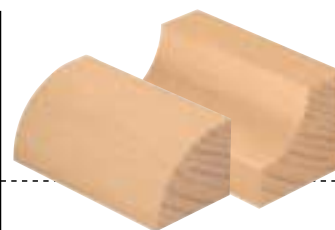
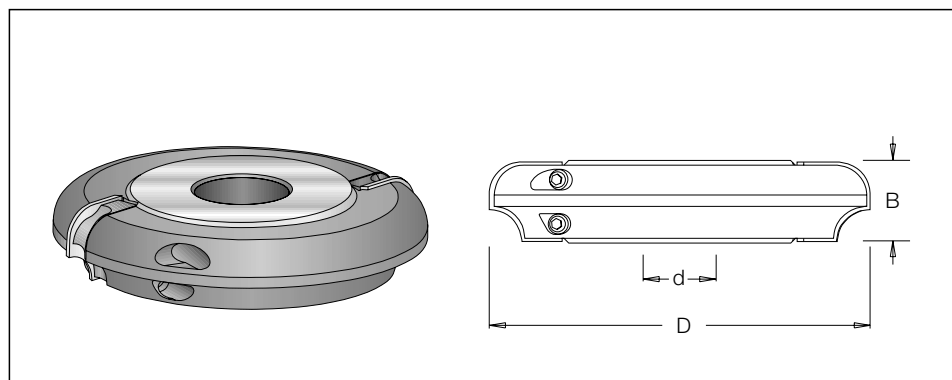

Aluminum



EN847-1
EN847-2



Hand feed

øD	B	Code No.	R	ød	n
106	20	751 103 1	3	30	7,300 - 10,100
110	20	751 105 1	5	30	7,000 - 9,900
112	20	751 106 1	6	30	6,900 - 9,700
116	20	751 108 1	8	30	6,600 - 9,500
120	25	751 110 1	10	30	6,400 - 10,000
124	30	751 112 1	12	30	6,200 - 9,800
130	35	751 115 1	15	30	5,900 - 9,500
140	50	751 120 1	20	30	5,500 - 9,000
150	60	751 125 1	25	30	5,100 - 6,000
160	60	751 130 1	30	30	4,900 - 5,800

Spare parts:



T.C. Blade



Wedge



Allen screw



Allen key

R3	#310 894 4 R3	#199 091 0 L=18	#193 026 5 M6x16	#194 003 5 S3
R5	#310 894 6 R5	#199 091 0 L=18	#193 026 5 M6x16	#194 003 5 S3
R6	#310 894 7 R6	#199 091 0 L=18	#193 026 5 M6x16	#194 003 5 S3
R8	#310 894 9 R8	#199 091 0 L=18	#193 026 5 M6x16	#194 003 5 S3
R10	#310 895 0 R10	#199 092 0 L=23	#193 026 5 M6x16	#194 003 5 S3
R12	#310 895 2 R12	#199 092 5 L=28	#193 026 5 M6x16	#194 003 5 S3
R15	#310 895 3 R15	#199 093 0 L=33	#193 026 5 M6x16	#194 003 5 S3
R20	#310 895 4 R20	#199 094 0 L=48	#193 026 5 M6x16	#194 003 5 S3
R25	#310 895 5 R25	#199 095 0 L=58	#193 026 5 M6x16	#194 003 5 S3
R30	#310 895 6 R30	#199 096 0 L=58	#193 026 5 M6x16	#194 003 5 S3

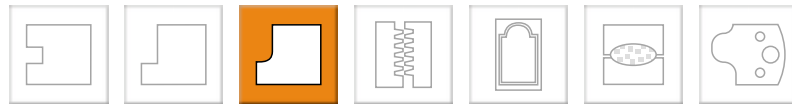

Grooving Rebating **Profiling** Jointing Frame & Panel door Lamello Multi Profile system

Multi Round Over Cutter

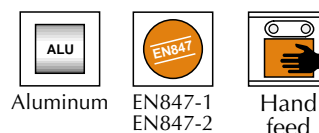
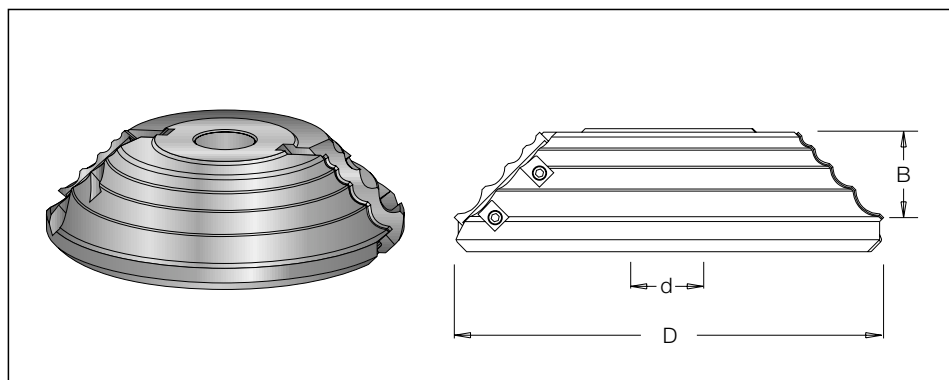

øD	B	Code No.	R	ød	n
140	18	752 109 1	2,3,5	30	5,400 - 8,800
180	25	752 110 1	4,6,8,10	30	4,500 - 7,500

Spare parts:

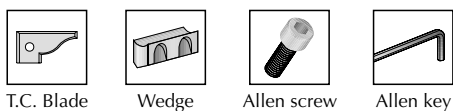

R = 2, 3, 5

#310 855 0	#199 048 6	#193 026 5	#194 003 5
R=2, 3, 5	L=24	M6x16	S3

R = 4, 6, 8, 10

#310 854 9	#199 048 5	#193 026 5	#194 003 5
R=4, 6, 8, 10	L=48	M6x16	S3

Multi Cove Cutter

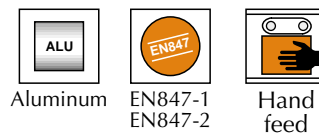
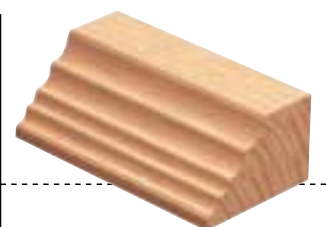
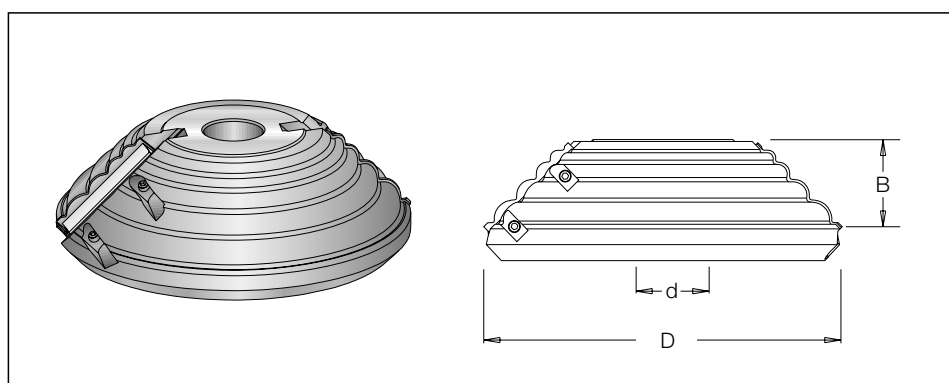

øD	B	Code No.	R	ød	n
180	43	752 201 1	4,6,8,10	30	4,500 - 7,500

Spare parts:

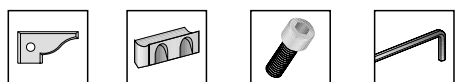

T.C. Blade	Wedge	Allen screw	Allen key
#310 856 0	#199 047 5	#193 026 5	#194 003 5
60x20x2	L=58	M6x16	S3

NOVA Cutting

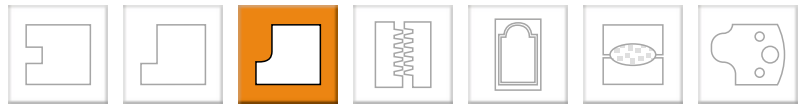

Grooving Rebating **Profiling** Jointing Frame & Panel door Lamello Multi Profile System

Multicut Set

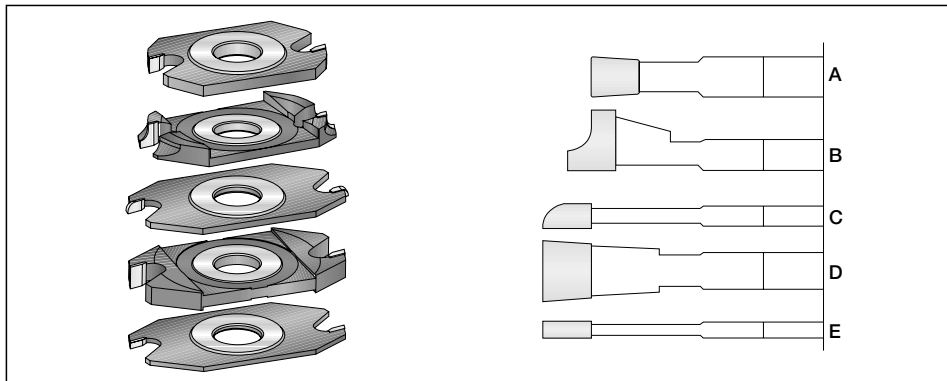

Hand feed

	øD	Code No.	Width	n
Multicut set Includes 5 cutters and a set of distance rings		711 001 1		5,500 - 9,600
Cutter A	116	711 021 1	10	5,500 - 9,600
Cutter B	127	711 031 1	15	5,500 - 9,600
Cutter C	140	711 041 1	16	5,500 - 9,600
Cutter D	140	711 051 1	15	5,500 - 9,600
Cutter E	140	711 061 1	14	5,500 - 9,600

Spare parts:



Spacer set
#711 065 1

! Set of 5 cutters with 2 carbide teeth each. Combined, they enable execution of various profiles, counter - profile and panels.

If necessary, spacers are laid between the hubs. Chip - limitation design to comply with safety regulations.

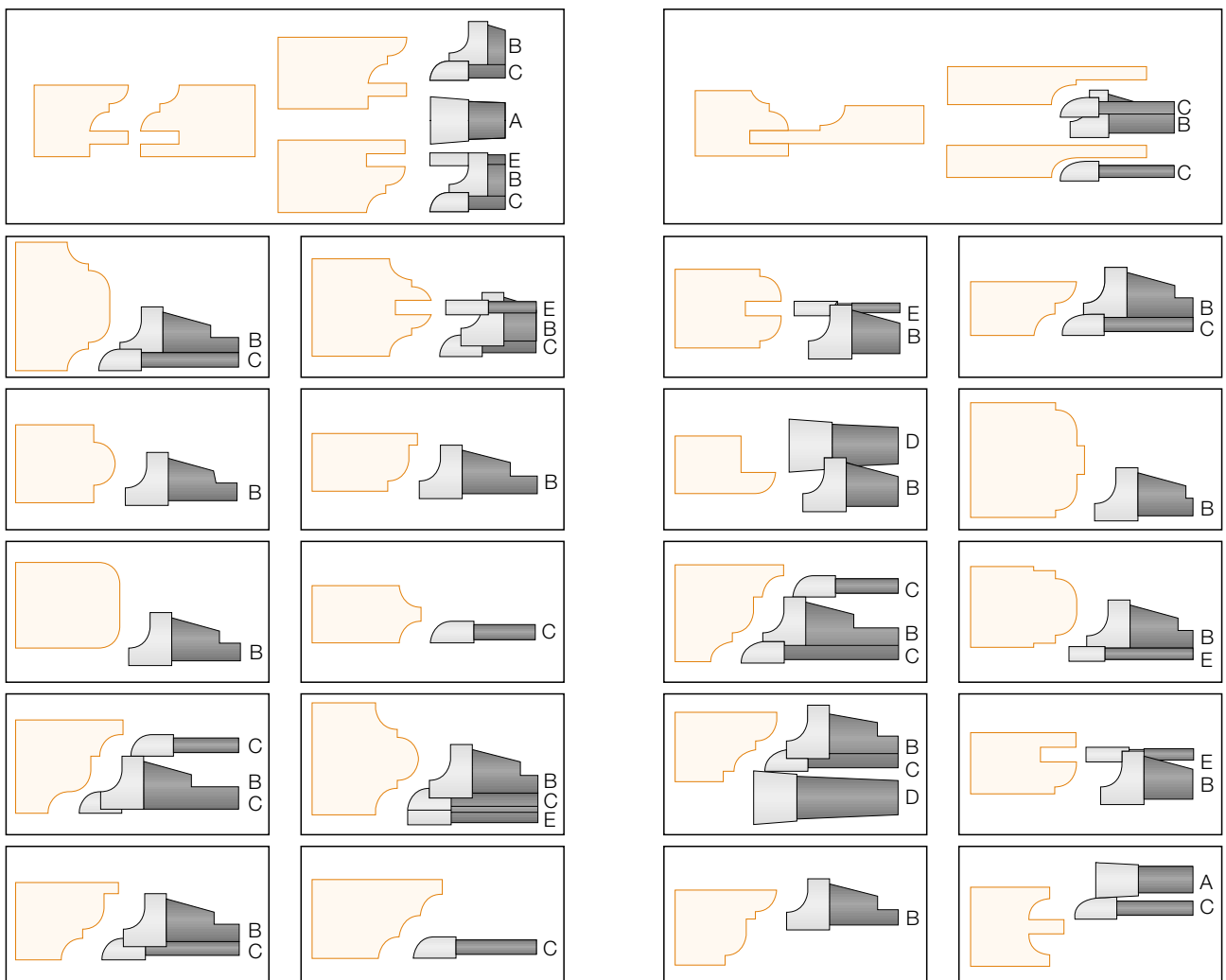



NOVA Cutting

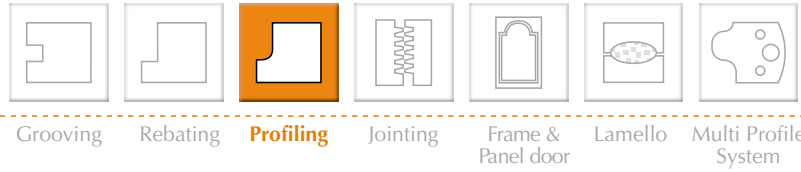

Custom Made Profile Cutters

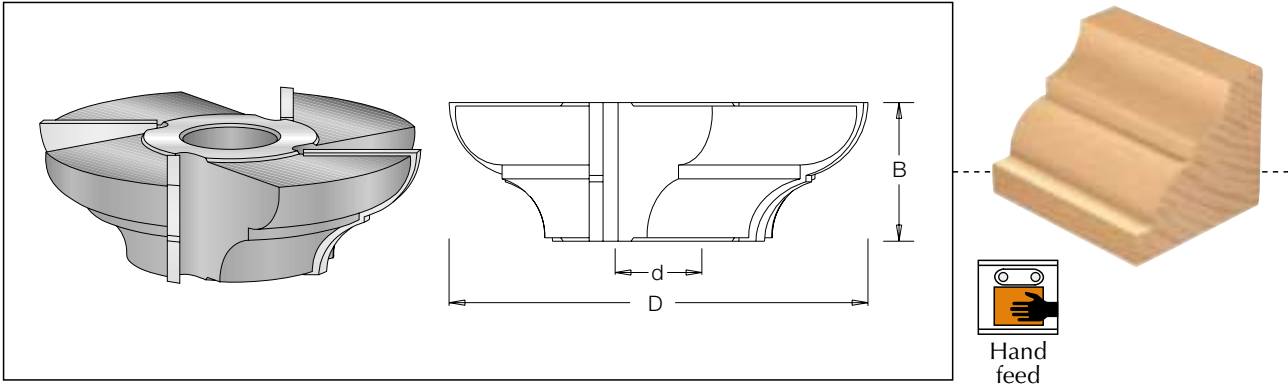

Diameter	80	100	125	150	180	200							
Teeth	2,3,4	2,3,4	2,3,4,6	2,3,4,6	2,3,4,6	2,3,4,6							
Width (mm)	15	20	25	30	35	40	45	50	60	70	80	90	100
Scheme													

! Profile Cutters are made to order.
The division of 3 main groups as an indication only.

When ordering please state:
1. Group 2. Profile number in the group 3. Diameter
4. Number of teeth 5. Cutting width 6. Scheme.
Standard bore 30mm, others on order.

Group A

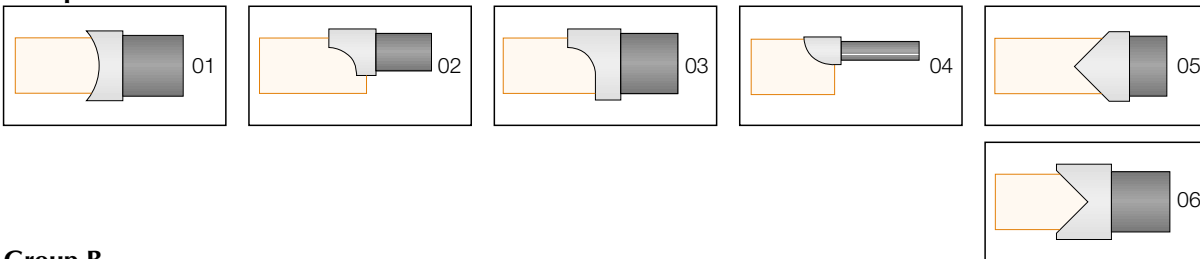

Group B

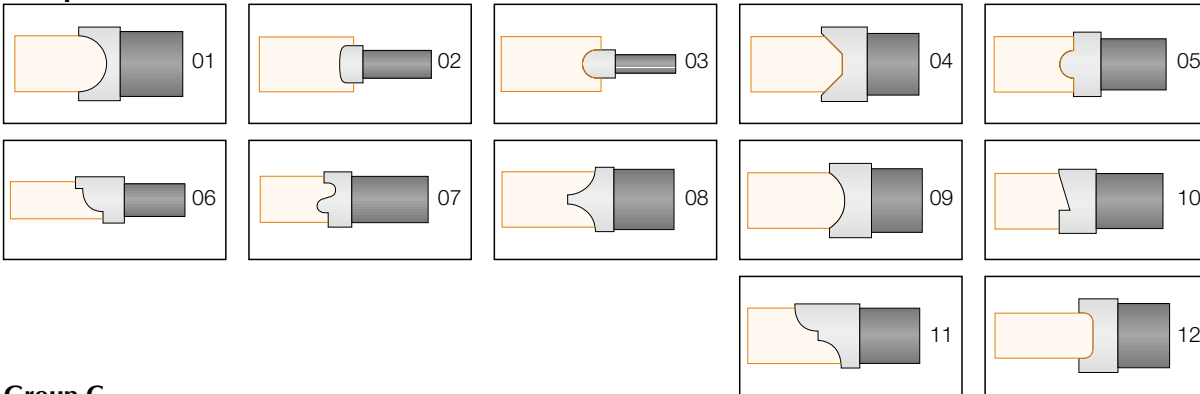

Group C

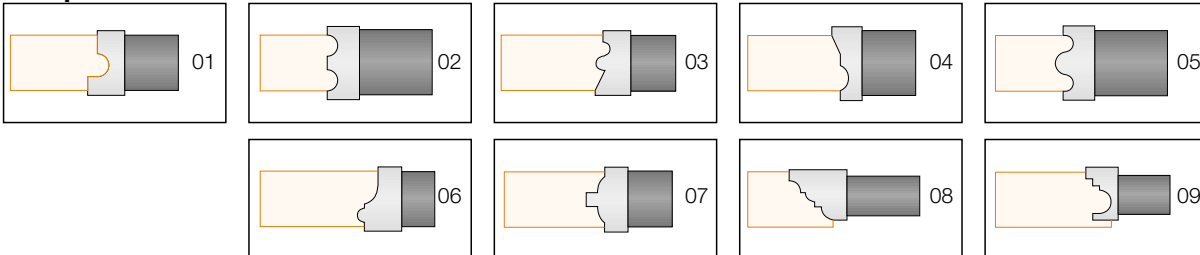

NOVA Cutting

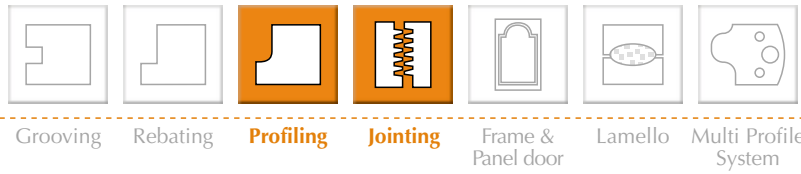

Handrail Cutter

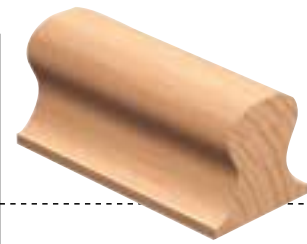
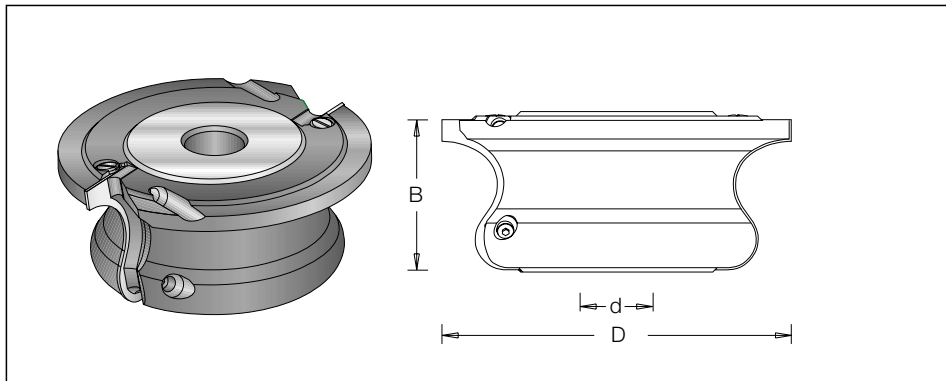

øD	B	Code No.	Profile	ød	n
130	73	752 510 1	A	30	5,800 - 7,700
160	73	752 515 1	B	30	4,700 - 7,200

Spare parts:

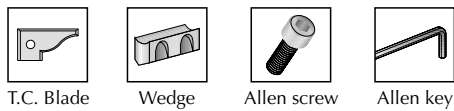

	T.C. Blade	Wedge	Allen screw	Allen key
Profile A	#310 887 0 69.5x33.5x2	#199 085 0 L=63	#193 026 7 M8x16	#194 003 6 S4
Profile B	#310 887 1 70x34x2	#199 086 0 L=65	#193 026 7 M8x16	#194 003 6 S4

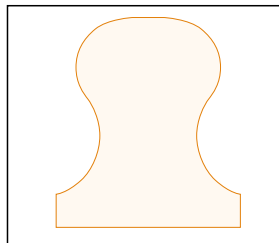

Profile A

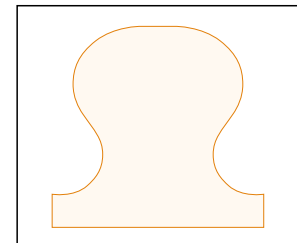

Profile B

Glue Joint Cutter

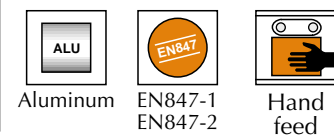
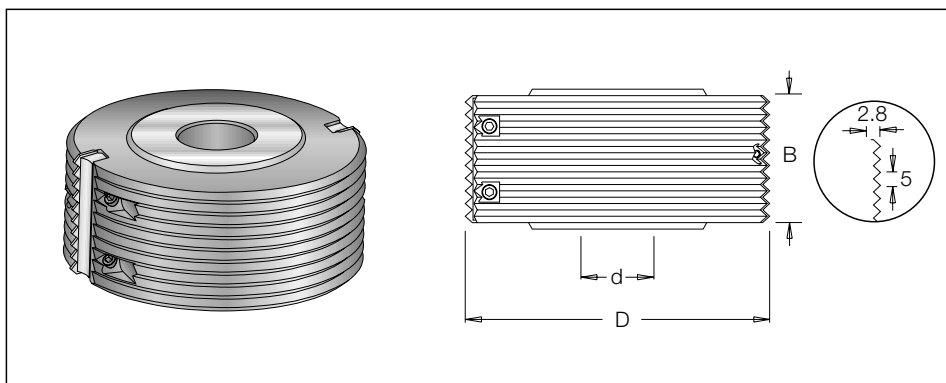

øD	B	Code No.	ød	n
90	50	741 000 1	30	8,500 - 12,000
120	50	741 001 1	30	6,100 - 10,000

Spare parts:

T.C. Blade	Wedge	Allen screw	Allen key
#310 850 7 50x12x1.5	#199 049 5 L=48	#193 049 5 M6x12	194 003 5 S3