

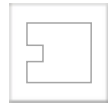

# NOVA Cutting

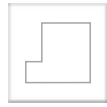

Grooving



Rebating

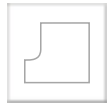

Profiling

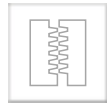

Jointing



Frame &  
Panel door

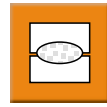

Lamello

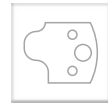

Multi Profile  
system

## Lamello - Biscuit Jointer Cutter

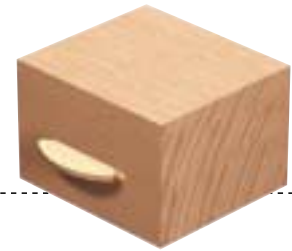
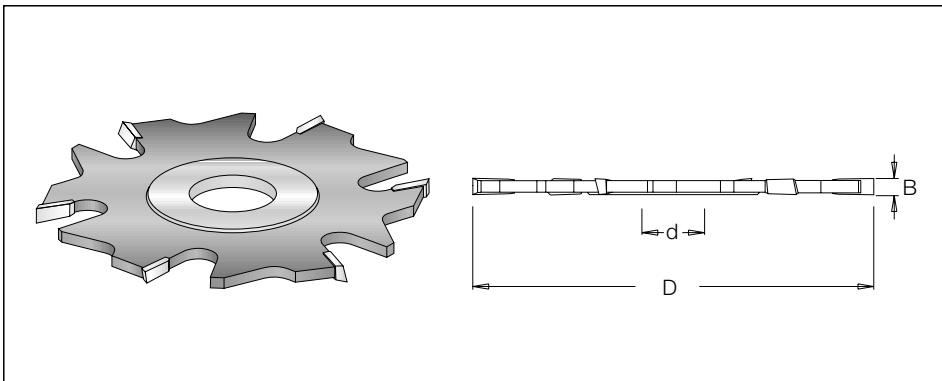

Hand  
feed

$\varnothing D$	B	Code No.	Teeth	$\varnothing d$	n
100	4	707 200 4	6	22	7,600 - 13,400

- ⚠ Cutter for joining Lamello. The width of the cutter is suited to the original Lamello joint plates. The size of the Lamello joint plates determine the depth of the penetration.
- 2 Teeth positive angle.
- 4 Teeth negative angle.

## Lamello - Biscuit Jointer Cutter

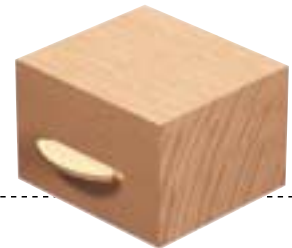
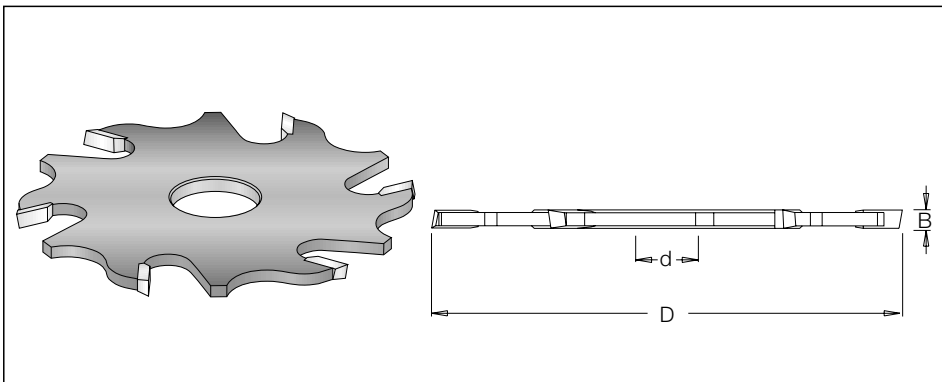

Hand  
feed

$\varnothing D$	B	Code No.	Teeth	$\varnothing d$	n
100	4	707 202 4	6	22	7,600 - 13,400

- ⚠ Cutter for joining Lamello. The width of the cutter is suited to the original Lamello joint plates. The size of the Lamello joint plates determine the depth of the penetration.
- All Teeth positive angle.

# NOVA Cutting

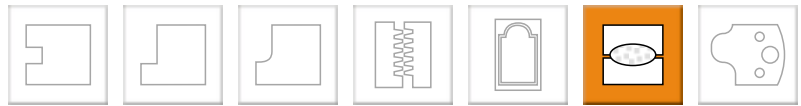

Grooving    Rebating    Profiling    Jointing    Frame & Panel door    **Lamello**    Multi Profile system

## Lamello - Biscuit Jointer Cutter

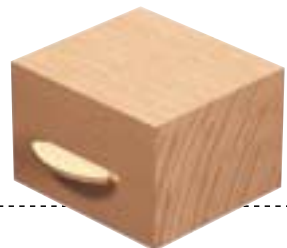
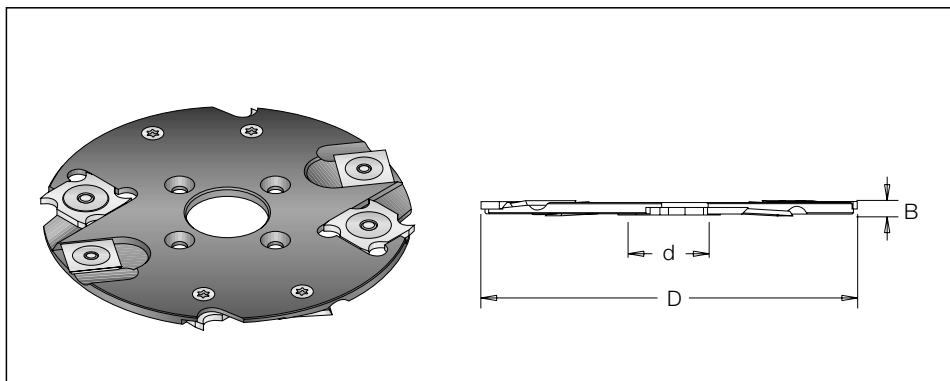

EN847-1  
EN847-2



Hand feed

øD	B	Code No.	Teeth	ød	n
100	4	721 020 4	4+4	22	7,700 -15,000

### Spare parts:



T.C. Blade  
#300 850 1  
18x18x2



T.C. Blade  
#300 850 2  
14x14x1.2



T.C. Blade Nut  
#192 350 0  
M4x0.5x11



T.C. Blade Nut  
#192 350 0  
M4x0.5x9.9



Torx screw  
#193 028 0  
M4x3.2



Torx key  
194 110 0  
T9



# NOVA Cutting

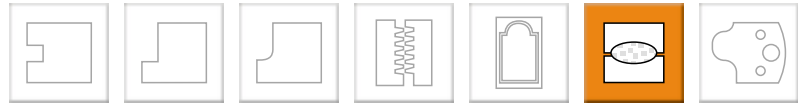

Grooving    Rebating    Profiling    Jointing    Frame & Panel door    **Lamello**    Multi Profile system

## Lamello - Resin Pocket Cutters

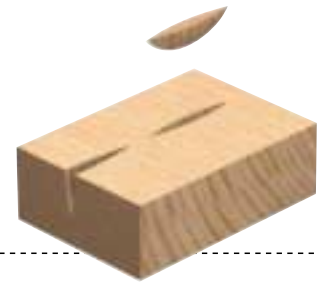
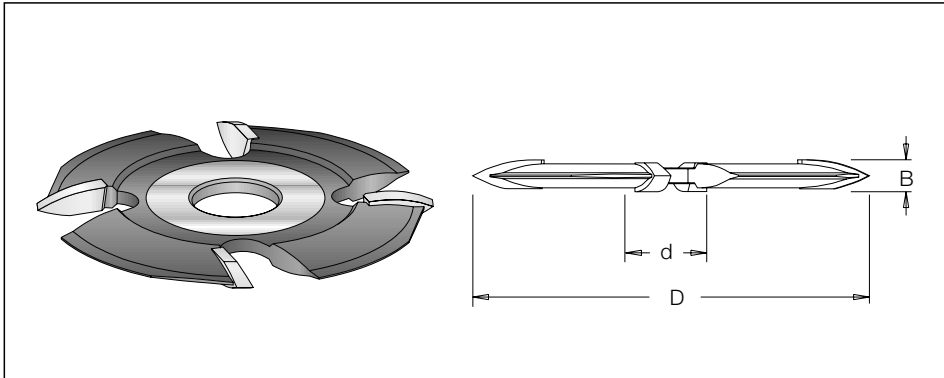

$\varnothing D$	B	Code No.	Teeth	$\varnothing d$	n
100	8	707 520 4	4	22	7,700 - 1,500
	15	707 525 4	4	22	7,500 - 13,400

**!** Cutter for manual feed. Mini-spot cutters designed for cutting out the resin pockets.

## Lamello - Resin Pocket Cutters

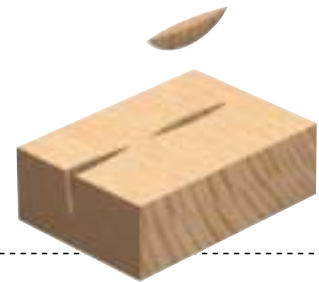
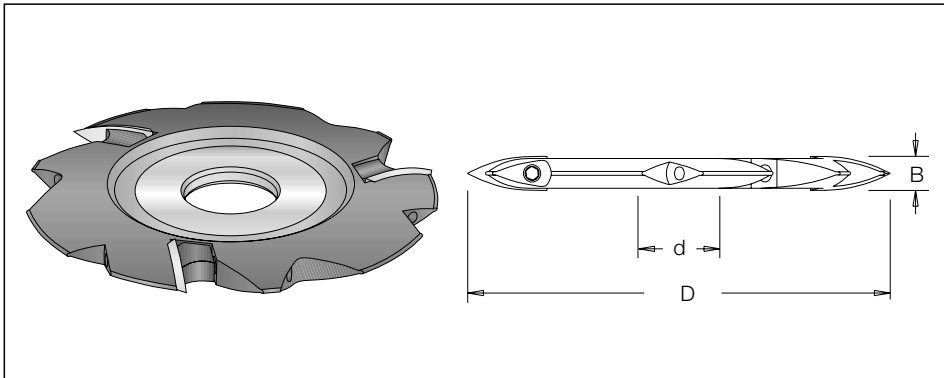

$\varnothing D$	B	Code No.	Teeth	$\varnothing d$	n
100	8	721 025 4	3	22	7,700 - 15,000

### Spare parts:



T.C. Blade  
#310 858 2  
8x20x2



Wedge  
#199 031 2  
L = 6



Allen screw  
#193 060 0  
M56x16



Allen key  
#194 008 0  
S2.5