

Ripping
Sizing & Cutting

Scoring

Hogging

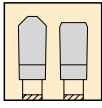

MUP - Plastic Trimming & Sizing Saw Blade

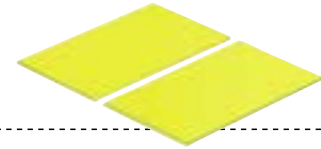
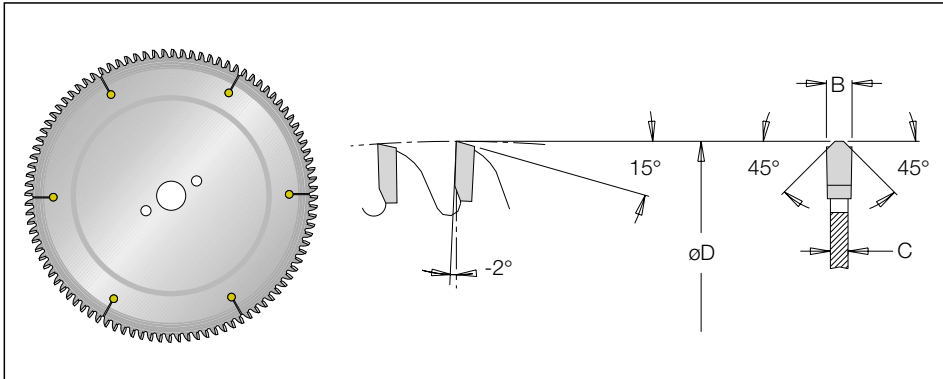

Plastic

$\varnothing D$	Teeth	Code No.	B	c	$\varnothing d$
250	80	901 07 03 6	2.5	1.8	30
300	96	901 07 06 6	3.3	2.6	30
350	108	901 07 09 6	3.7	3.0	30

Manufacturing Technology:



Balance

Dynamic
Straightness

Tension