

Ripping
Sizing & Cutting

Scoring

Hogging

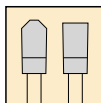

DST - Main Saw for Panel Sizing Laminated Boards Extended Life

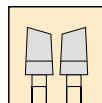
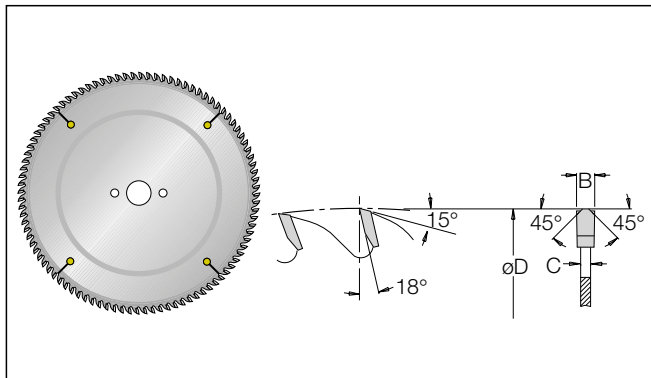

DVK - Scoring Extended Life

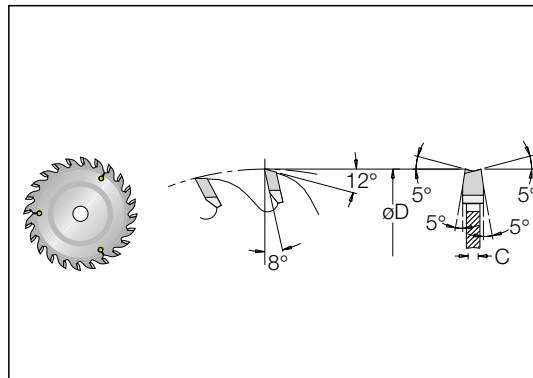

Type	øD	Teeth	Code No.	B/C	ød	NI	
Scher	400	72	95531296	4.25/3.2	30		
	305	60	95531056	4.4/3.0	30		
Panhans	355	54	95531106	4.4/3.0	30		
	355	72	95531156	4.4/3.0	30		
	355	54	9553110T	4.4/3.0	75		
	355	72	9553115T	4.4/3.0	75		
	400	60	9553125T	4.4/3.2	75	4/15/105	
	400	72	9553130T	4.4/3.2	75	4/15/105	
	430	72	9553150T	4.4/3.2	75	4/15/105	
	Giben	430	96	9553155T	4.4/3.2	75	4/15/105
470		96	9553175T	4.4/3.2	75	4/15/105	
500		72	9553190T	4.4/3.2	75		
500		72	9553195T	4.8/3.5	75		
500		72	9553200T	5/3.5	75		
550		72	9553230Z	5/3.5	100		
Scm		355	54	95531106	4.4/3.0	30	
		355	72	95531156	4.4/3.0	30	
Gabbiani	355	72	9553115U	4.4/3.0	80	4/9/100	
Scm						2/14/110	
						2/7/110	
Holzma	380	72	9553123R	4.8/3.5	60		
	400	72	9553130R	4.4/3.2	60		
	400	72	9553134R	4.8/3.2	60		
	420	72	9553135R	4.4/3.2	60		
	420	72	9553140R	4.8/3.5	60		
	450	72	9553160R	4.4/3.2	60		
	450	72	9553170R	4.8/3.5	60	2/14/125	
	500	60	9553185R	4.8/3.5	60		
	500	72	9553195R	4.8/3.5	60		
	500	72	9553200R	5/3.5	60		
	570	96	9553235R	4.8/3.5	60		
	600	72	9553301R	5.8/4.0	60	2/19/120	
Schelling						2/11/115	
	355	72	95531156	4.4/3.2	30		
	400	60	95531256	4.4/3.2	30		
	400	72	95531306	4.4/3.2	30		
	450	72	95531606	4.4/3.2	30		
	500	72	95531906	4.4/3.2	30		
	530	60	9553210R	5/3.5	60		
	550	72	95532309	5/3.5	40		

øD	Teeth	Code No	B/C	ød	NI
400	72	95531306	4.4/3.2	30	
125	24	95600793	4.4/3.2	20	
125	24	95600793	4.4/3.2	20	
125	24	95600793	4.4/3.2	20	
125	24	9560079M	4.4/3.2	45	
125	24	9560079M	4.4/3.2	45	
160	36	9560195M	4.4/3.2	45	
160	36	9560195M	4.4/3.2	45	
216	42	9560270N	4.4/3.2	50	3/15/80
300	48	9560280N	4.4/3.2	50	3/15/80
216	42	9560270N	4.4/3.2	50	3/15/80
300	48	9560280N	4.4/3.2	50	3/15/80
216	42	9560270N	4.4/3.2	50	3/15/80
300	48	9560280N	4.4/3.2	50	3/15/80
125	24	9560079M	4.4/3.2	45	
180	30	9560215C	5/3.5	55	
160	36	9560195C	4.4/3.2	55	3/7/66
200	36	9560261M	4.8/3.5	45	
340	48	9551108M	5/3.5	45	
340	108	9551109M	5/3.5	45	
180	30	9560216M	4.8/3.5	45	
340	108	9551109M	5/3.5	45	
340	108	9551109M	5/3.5	45	
340	108	9551109M	5/3.5	45	
340	108	9551109M	5/3.5	45	
340	108	9551109M	5/3.5	45	
340	108	9551109M	5/3.5	45	
200	36	95602653	4.4/3.2	20	
150	24	95600883	4.4/3.2	20	
200	36	95602653	4.4/3.2	20	
180	30	95602103	4.4/3.2	20	
200	36	95602623	5/3.5	20	
200	36	95602623	5/3.5	20	



NOVA Sawing

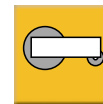
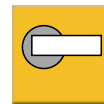

Ripping
Sizing & Cutting

Scoring

Hogging

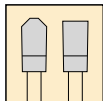

DST - Main Saw for Panel Sizing Laminated Boards Extended Life

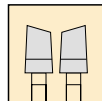
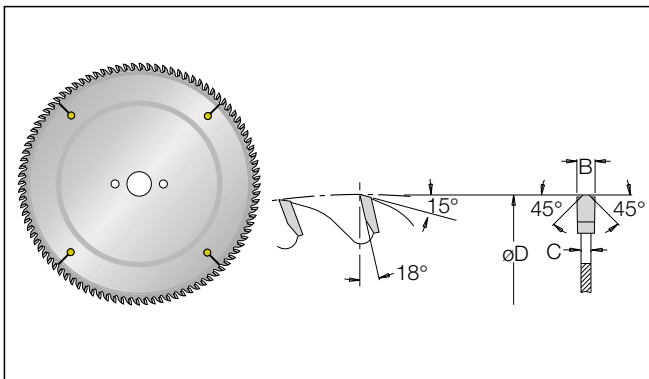

DVK - Scoring Extended Life

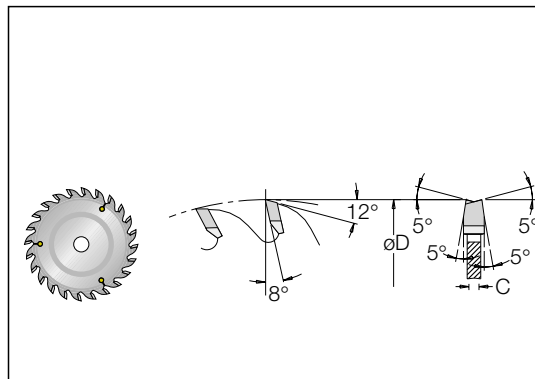

Type	øD	Teeth	Code No.	B/C	ød	NI
Anthon	400	72	9553130R	4.4/3.2	60	
	430	72	9553150R	4.4/3.2	60	11/1/85
	530	60	9553220R	5.8/4.0	60	
	400	72	9553132U	4.4/3.2	80	4/19/120+ 2/9/130
Selco	430	72	9553150U	4.4/3.2	80	"
	450	72	9553160U	4.4/3.2	80	"
	450	72	9553170U	4.8/3.5	80	"
Mayer	305	60	95531056	4.4/3.0	30	
	355	54	95531106	4.4/3.0	30	
	355	72	95531156	4.4/3.0	30	
	400	72	95531306	4.4/3.0	30	
S.m.a	355	72	9553115U	4.4/3.0	80	4/9/100
	400	72	9553133U	4.4/3.2	80	2/7/110+ 2/9/130
	430	72	9553152U	4.4/3.2	80	"
	450	72	9553162U	4.4/3.2	80	"
500	72	9553190U	4.4/3.2	80		

øD	Teeth	Code No.	B/C	ød	NI
180	30	95602103	4.4/3.2	20	
180	30	95602103	4.4/3.2	20	
180	30	95602203	5.8/4.0	20	
200	36	9560265S	4.4/3.2	65	2/9/110
300	72	9551106S	4.6/3.2	65	
300	72	9551106S	4.6/3.2	65	
200	36	9560261S	4.8/3.5	65	2/9/110

Manufacturing Technology:



Dynamic
Balancing



Dynamic
Straightness



Tension